

Non contact
3D optical
profiler

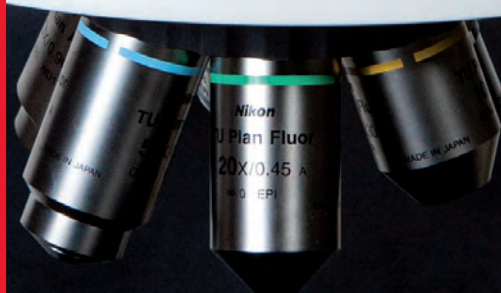

SENSOFAR



SENSOFAR®



3D Optical Profiler



Sensofar's S line

Feel the

The new S line for non-contact optical 3D profiling. The line that opens the gate to a new 3D experience.

Designed as a high-performance 3D optical profiler from the outset, S neox outperforms all existing optical profilers, combining confocal and interferometry techniques in the same sensorhead without any moving parts.

S neox, the best of two techniques.

3D experience

Confocal

Confocal profilers have been developed to measure the surface height of smooth to very rough surfaces. Confocal profiling provides the highest lateral resolution that can be achieved by an optical profiler. Thus, spatial sampling can be reduced to $0.10\ \mu\text{m}$, which is ideal for critical dimension measurements. High NA (0.95) and magnification (150X) objectives are available to measure smooth surfaces with steep local slopes over 70° (for rough surfaces up to 86°). The proprietary confocal algorithms provide vertical repeatability on the nanometer scale.

Interferometry

PSI Phase shift interferometers have been developed to measure the surface height of very smooth and continuous surfaces with sub-nanometer resolution. PSI profiling provides sub-nanometer vertical resolution for all numerical apertures (NA). Very low magnifications (2.5X) can be employed to measure large fields of view with the same height resolution.

VSI White-light vertical scanning interferometers have been developed to measure the surface height of smooth to moderately rough surfaces. VSI profiling provides nanometer vertical resolution for all NAs. The VSI algorithms enable the S neox to use all the available magnifications to profile shape features with the same height resolution.

Confocal with no moving parts

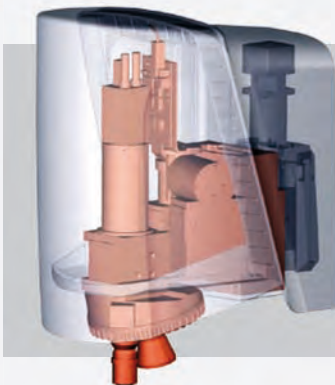

For confocal scanning, the neox uses the Sensofar's patented technology, which is based on a microdisplay. The microdisplay is based on ferroelectric liquid crystal on silicon (FLCoS), a fast switching device with no moving parts that makes the scanning of confocal images fast and very stable with an unlimited lifetime. Existing confocal microscopes use mirror scanning heads, which are movable mechanisms that limit lifetime and degrade pixel dithering at high magnifications.

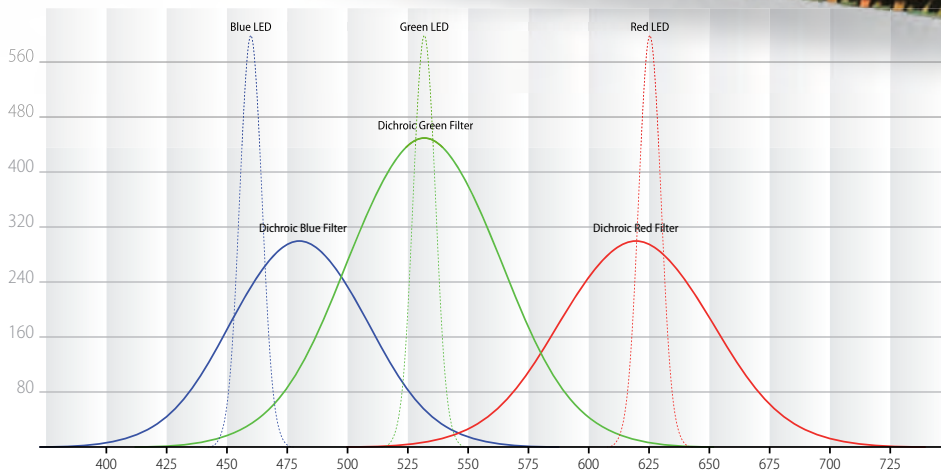
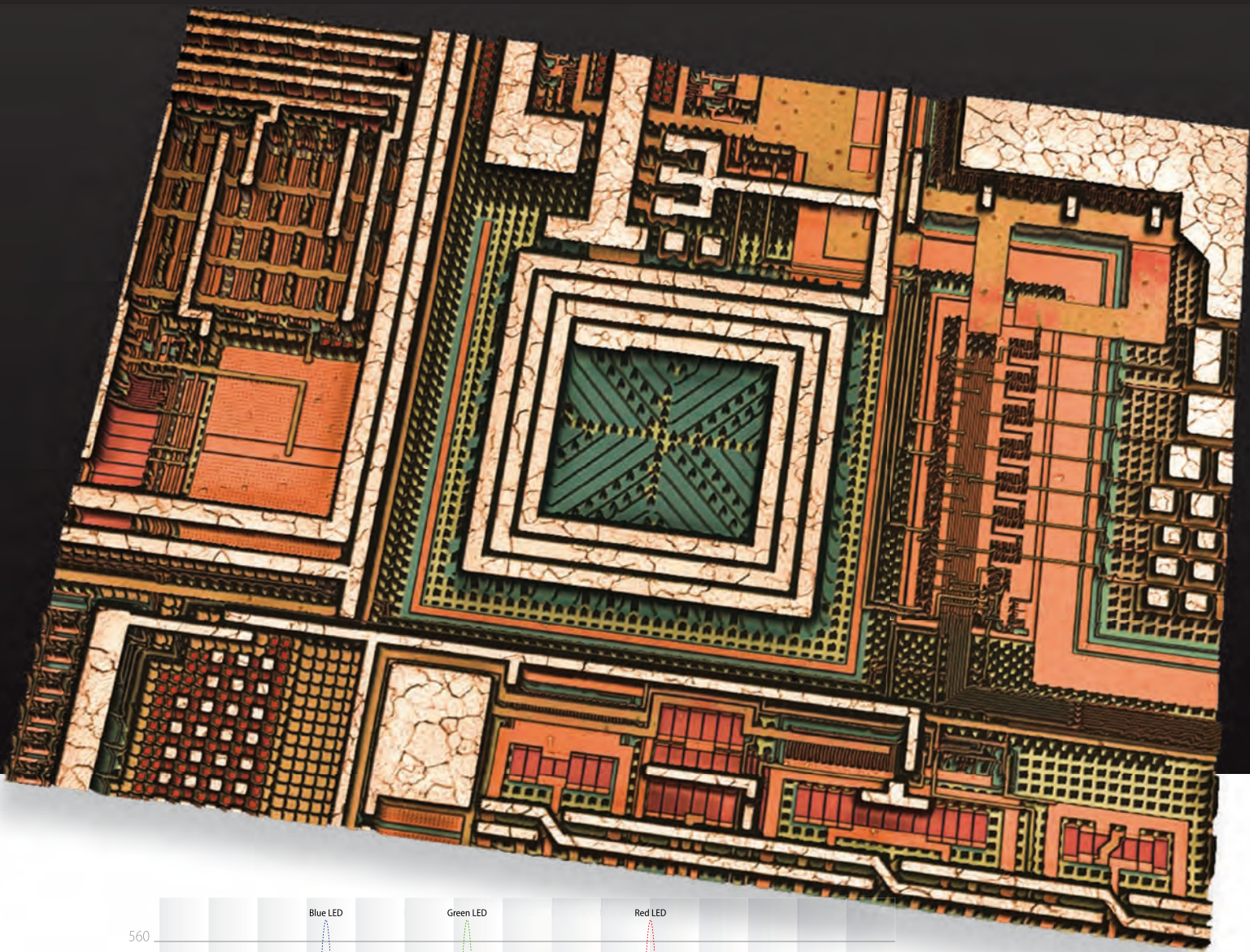

Multispectral wavelength LEDs

Red. Green. Blue. White.

Focused on optimizing the light source for each application, S neox has four LED light sources inside its optical core: red (630 nm), green (530 nm), blue (460 nm) and white. Shorter wavelength is used on those applications where the highest lateral resolution is required.

Longer wavelengths provide greater optical coherence, up to 20 μm , making Phase Shifting Interferometry possible on large area smooth surfaces. Additionally, the red, green and blue LEDs are pulsed to acquire real color images and high contrast color-coded depth information in real time.

Amazing image quality

See the big picture

The S neox uses a high-resolution CCD sensor of up to 1360x1024 pixels in combination with high-resolution displays of 2560x1440. The images acquired with S neox do not need to be up-scaled or down-scaled, so they always appear sharp, vivid and realistic on-screen.

Sequential color

Each pixel in real color

Red, green and blue LEDs are used to sequentially illuminate the surface under inspection. Three monochromatic images are taken and compounded into a high resolution color image. The benefits of this approach are high color fidelity and saturation, as well as real pixel-to-pixel color information. In contrast to color cameras based on a Bayer matrix of pixels, the S neox does not need to interpolate the color information between pixels.

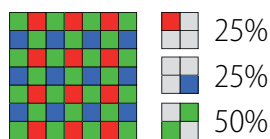
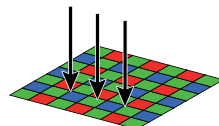

Bayern Matrix

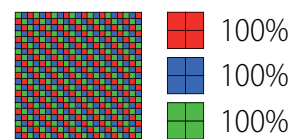
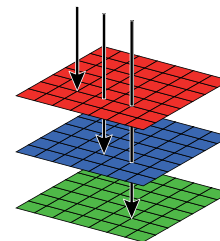
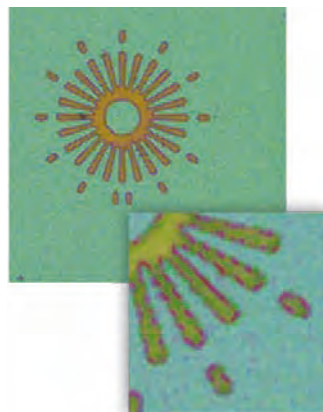

Sensofar's S neox



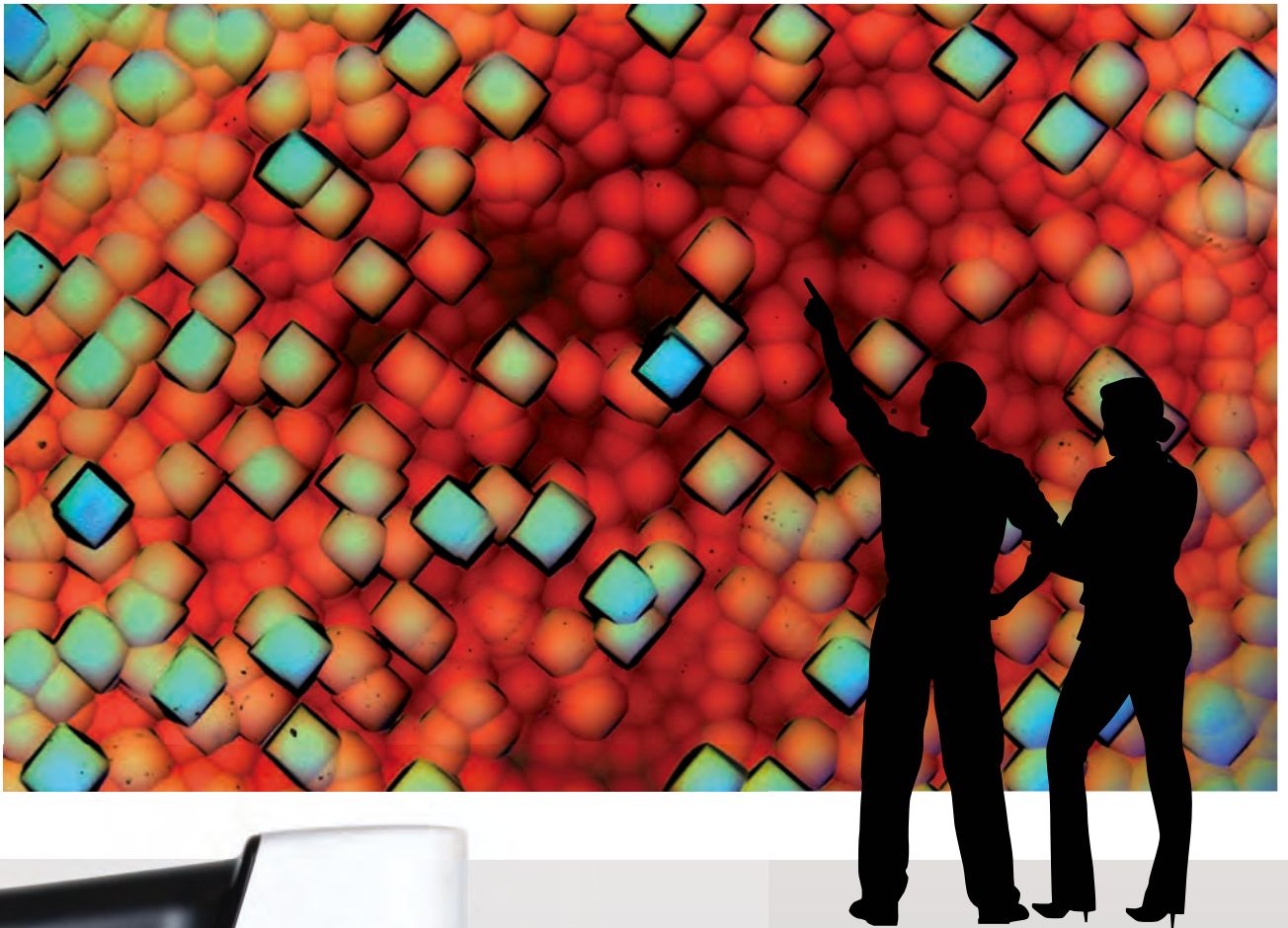

Live 3D feelings

A new way to feel the 3D experience

A confocal RGB image view technique allows the user to observe nano-level details within a few microns range. The red, green and blue LEDs are sequentially pulsed and synchronized to acquire three confocal images. The result is color-coded depth information determined from the chromatic depth distortion of the microscope objective, resulting in a pseudo-color topography with qualitative information of the height of the topography.

Highest level of details

From nanoworld to your eyes

Confocal images are taken at the highest camera resolution with very impressive details.

A complete 3D scan is taken in less than 10 seconds.
For high-speed applications and extremely low reflective surfaces, the camera is binned at 2x2, making it possible to acquire an incredible full 3D scan in less than 3 seconds.

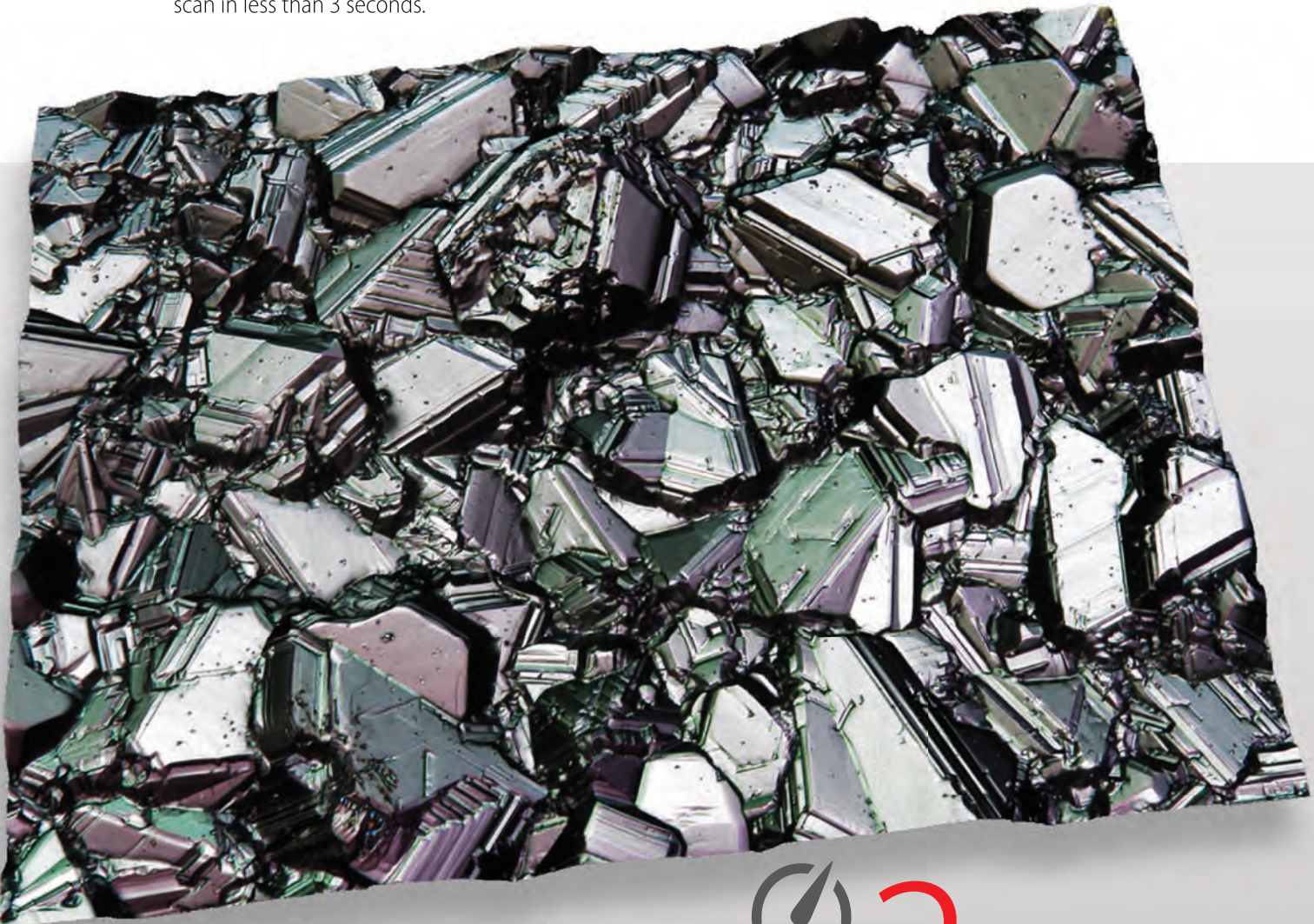

Incredible
full 3D scan
in less than **3s**

S

neox

SENSOFAR

The S neox uses premium CF60-2 Nikon objectives lenses that have been designed to correct for chromatic aberrations and produce sharp, flat and clear images with high contrast and high resolution. Phase Fresnel lenses improve the operability and the working distance, meaning that S neox objectives provide the largest available working distance for each NA.

The highest quality objectives,
the highest quality performance

Outstanding lateral resolution

According to the well-known **Rayleigh** resolution criterion, two points are resolved when the first minimum of one Airy disk is aligned with the central maximum of the second Airy disk.

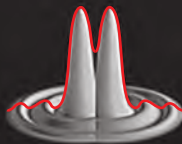

$$R_{\text{lateral}} = K \cdot \lambda / NA$$

Lateral resolution is improved when a short wavelength λ and a very high **NA** objective are used. K-factor is related with the width of the Airy disk and depends on the imaging conditions. Confocal technique reduces by about 30 percent the lateral extent of the Airy disk compared to that in a widefield microscope. Additional reduction of the K factor is obtained when incoherent illumination is used instead of a coherent light source (laser illumination).

Therefore, S neox outperforms CLSM and provides the best lateral and axial resolutions that can be attained in an optical profiler.

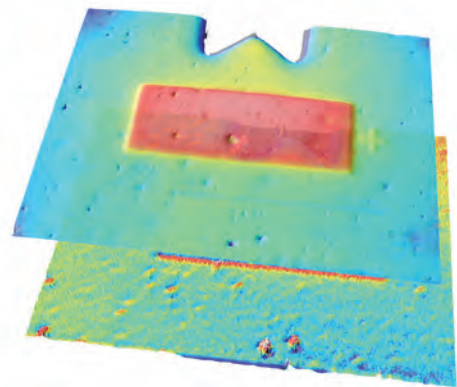

Thin & thick films

A full range solution is provided for thin and thick films with the optional spectroscopic reflectometer. As a flexible system, S neox can incorporate a spectroscopic reflectometer, coupled through an optical fiber, for the measurement of thin films with thicknesses ranging from 10 nm and up to 10 layer stacks. The optical fiber is imaged through the microscope's objectives. Thus, thin films can be measured with spots as small as 5 μm . The measurement is undertaken with the integrated LED light source, thus providing real-time bright-field images of the sample and simultaneous thin film measurements.



Multiple configurations

Sample size is important for us

The S neox is a complete tool. Its compact design is ideal for obtaining a fast, non-invasive assessment of the micro- and nanogeometry of technical surfaces in multiple configurations.

What size do you need?

Choose from portable to XXL systems

S neox provides the flexibility, durability and efficiency required from the standard setup for R&D and quality inspection laboratories to sophisticated, customized solutions for online process controls, measuring samples up to 700 x 600 mm².

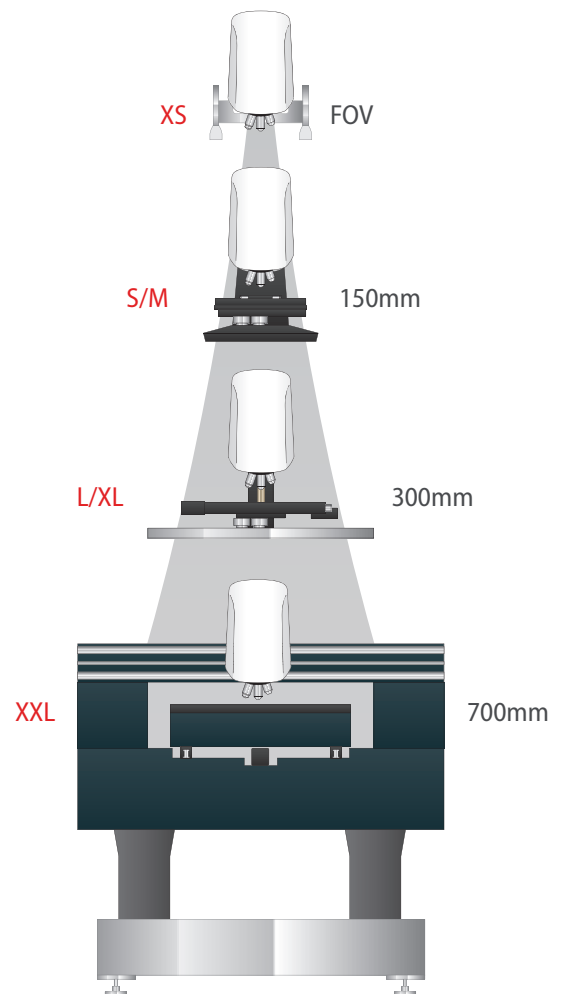



Acquisition & Analysis Software

SensoSCAN



Save time, make it easy for yourself

SensoSCAN software drives the S neo with its clear and intuitive friendly-interface. The user is guided through the 3D world, delivering a unique user experience. SensosCAN software provides an interface with which any measurement can easily be taken, as well as a basic set of tools for displaying and analyzing data.



Complete tool for a complete system

An overview tool helps the user to inspect the sample during measurement preparation, check measurement positions before acquisition as well as assist in the automation procedure. Work with high magnification will be easier, as you will know where you are at every moment.



Automating procedures

Automated measurements are obtained using the Recipes tool, an easily customizable tool for creating quality control procedures. It is ideal for online inspection, it is extremely easy to define procedures for automating measurements with the profile manager tool, sample identification, data exportation and 'pass or fail' criteria.

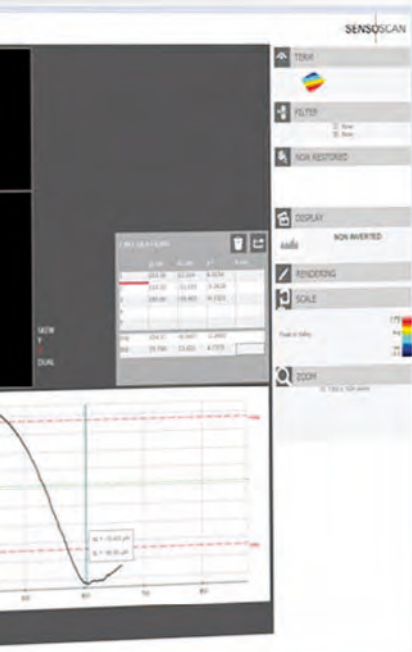

Everything is fast, really fast

Thanks to our dedicated algorithms, the S neox allows results to be acquired in less than a minute after the sample has been positioned. Naturally any data acquisition is still made following our obsession for the best quality and performance.

Powerful Analysis Software ...need more?

A fully automated process (measurement and analysis) can be undertaken in combination with two external software applications: SensoPRO or SensoMAP.

SensoPRO LT

It has never been so easy and fast to perform quality control in a production line. Thanks to SensoPRO LT, the operator in the production line only needs to load the sample and follow guided instructions. Plug-in-based data analysis algorithms provide a high degree of flexibility. Current capabilities include PSS module (Conic, Mesa and Merging LEDs), Bump, Hole, Roughness, Step Height, Traces and Trenches. New modules can be easily customized to other industry needs.

SensoMAP

SensoMAP, based on Mountains technology from Digital Surf, is an extremely powerful tool for analysis and reporting. SensoMAP software is completely modularly adaptable to customer requirements. Two levels (standard and premium) and several modules (2D, 3D or 4D modules, Advanced Contour, Grains & Particles, Statistics and Stitching) are available.

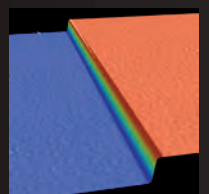
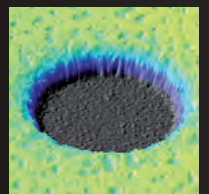
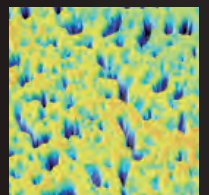
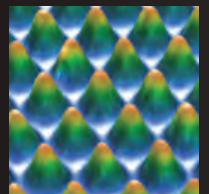
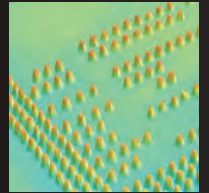



Focus on

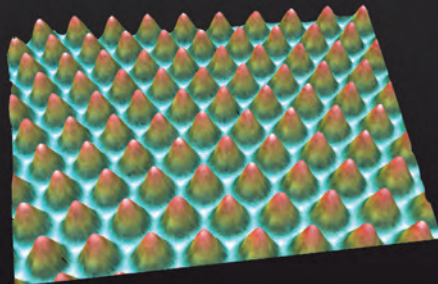

PSS

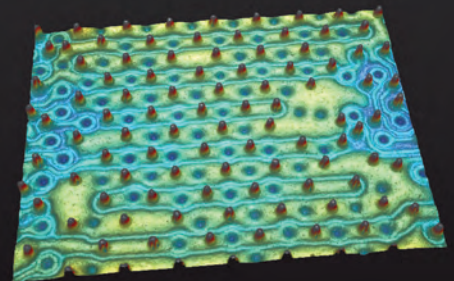

Solder balls

Applications

The S neox plays a key role in demanding industries such as the semiconductor, biomedical, and biotechnology industries.



Flat panel display



Innovation

your needs

After more than 10 years as a metrology consultancy and understanding the fast changes in the market, we have learned that opening the gate to innovation is the only way to make high-end products. Sensofar optical profilers are installed in hundreds of facilities and quality control departments for micro, nano and sub-nano applications that analyze the 3D surface characteristics of the material. The S neox has been developed as a versatile and multipurpose system that focuses on solving your application. Improving your quality control process and adding value to your products is where Sensofar wants to be.



Leather

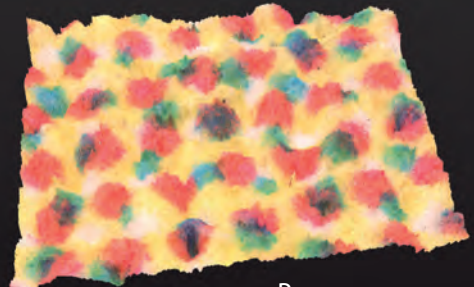

Paper

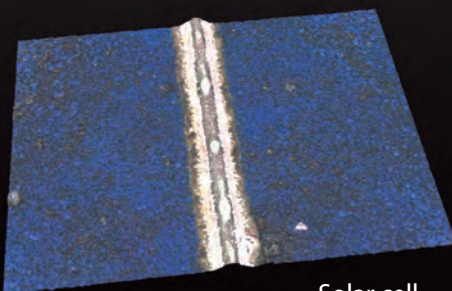

Solar cell

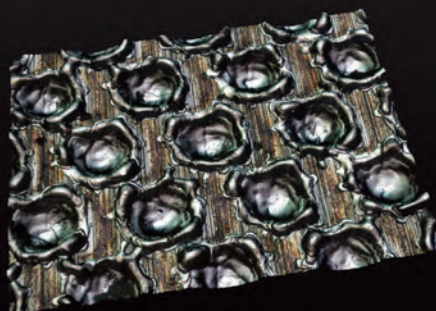

Texture surface
with electron beam

System configuration

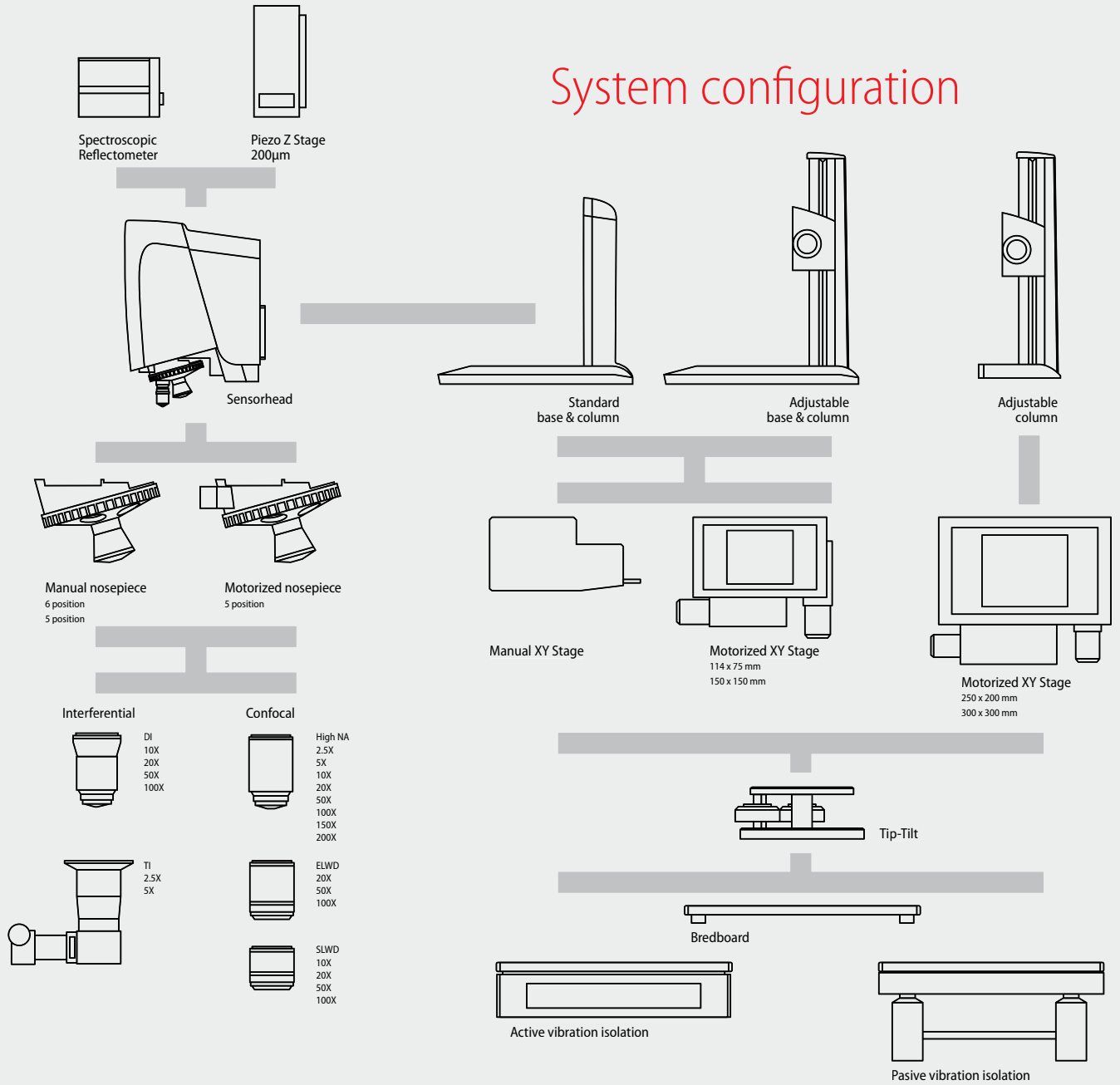

Dimensions unit: mm

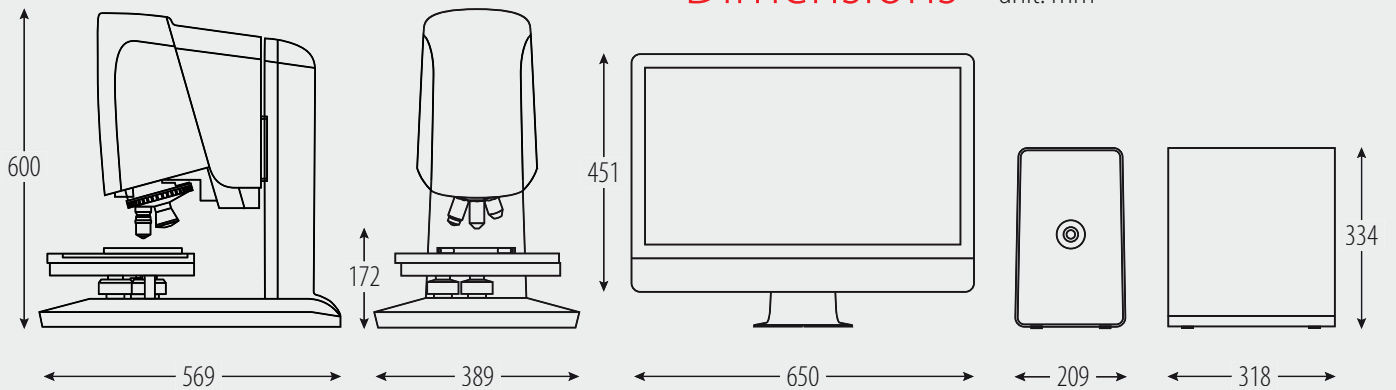

Objectives

	Brightfield						Interferometric					
MAG	5X	10X	20X	50X	100X	150X	2.5X	5X	10X	20X	50X	100X
NA	0.15	0.30	0.45	0.80	0.90	0.95	0.075	0.13	0.30	0.40	0.55	0.70
WD (mm)	23.5	17.5	4.5	1.0	1.0	0.2	10.3	9.3	7.4	4.7	3.4	2.0
FOV ¹ (µm)	3508x2640	1754x1320	877x660	351x264	175x132	117x88	7016x5280	3508x2640	1754x1320	877x660	351x264	175x132
Spatial sampling ² (µm)	2.58	1.29	0.65	0.26	0.13	0.09	5.16	2.58	1.29	0.65	0.26	0.13
Optical resolution ³ (µm)	0.93	0.46	0.31	0.17	0.15	0.14	1.87	1.07	0.46	0.35	0.25	0.20
Maximum slope ⁴ (°)	8	14	21	42	51	71	3	8	14	21	25	42
Vertical resolution ⁵ (nm)	75	25	8	3	2	1	PSI/ePSI 0.1 nm (0.01 nm with PZT)				VSI 1 nm	
Measurement time ⁶ (s)	>3s						>3s					

Other objectives are available.

For confocal: Water immersion, Super Long Working Distance, Extra Long Working Distance, Collar Ring depth focusing correction.

For interferometry: Variable reflectance, Michelson, Mirau and Linnik.

1 Maximum field of view with 2/3" camera and 0.5X optics.

2 Pixel size on the surface

3 L&S: Line and Space, half of the diffraction limit according to the Rayleigh criterion. Values for blue LED.

4 On smooth surfaces, up to 86° on rough surfaces

5 System noise measured as the difference between two consecutive measures on a calibration mirror placed perpendicular to the optical axis. For brightfield objectives, two confocal image averages. For interferometric objectives, PSI, 10 phase averages with vibration isolation activated. The 0.01 nm are achieved with Piezo stage scanner and temperature controlled room.

6 For brightfield objectives, 21 scanning planes. For interferometric objectives, 10µm scanning range.

System specifications

Measurement array	1360 x 1024 pixels
LED light sources	red (630 nm), green (530 nm), blue (460 nm) and white (550 nm)
Sample height	up to 40 mm (standard) ; 150 mm (adjustable) (larger under request)
XY sample size	up to 700 x 600 mm
Vertical range	40 mm with linear stage; 200 µm with piezo stage
Max. vertical scanning range	PSI 20 µm; ePSI 100 µm; VSI 10 mm
Z stage linearity	<0.5 µm/mm with linear stage and <30 nm/100 µm (0.03%) with piezo stage
Z stage resolution	2 nm with linear stage; 0.75 nm with piezo stage
Step height repeatability	0.1%
Step height accuracy	0.5%
Sample reflectivity	0.05% to 100%
Display resolution	0.001 nm
System	Line Voltage 100-240V AC, frequency 50/60Hz single phase
Computer	iMac 27" LED-backlit display with IPS technology; 2560 x 1440 pixels resolution
Operating system	Microsoft Windows 7
Environment	Temperature 10°C to 35°C Humidity <80% RH Altitude <2000 m





+info S neox

SENSOFAR is a leading-edge technology company that has the highest quality standards within the field of non-contact surface metrology.

We provide high accuracy optical profilers based on interferometry and confocal techniques. From standard setups for R&D and quality inspection laboratories to complete non-contact metrology solutions for online production processes, Sensofar offers technology that enables our customers to achieve breakthroughs, particularly in the semiconductor, precision optics, data storage, display devices, thick and thin film and material testing technologies fields. Sensofar is represented in over 20 countries through channel partners and has its own offices in Asia, Japan and the United States.



SENSOFAR®

HEADQUARTERS AND SALES OFFICE
SENSOFAR-TECH, SL.

Parc audiovisual de Catalunya
Crta. BV1274 Km 1
E-08225 Terrassa
Tel. (+34) 93 700 14 92
Fax (+34) 93 786 01 16
info@sensofar.com
www.sensofar.com

SALES OFFICE
SENSOFAR Japan Ltd.
Ichikawa Business Plaza 405,
4-2-5 Minami-Yawata
ICHIKAWA-SHI, CHIBA, 272-0023 (JAPAN)
Tel. (+81) 47 370 8600
Fax (+81) 47 370 8623
info@sensofar.co.jp
www.sensofar.co.jp

SENSOFAR LLC (USA)
PO Box 2013
Carefree AZ 85377
Tel. 1 800 530 3097
eFax 1 419 745 1516
info@sensofarusa.com
www.sensofarusa.com